

# DPP

## 30-100



27B



[www.enginplast.com](http://www.enginplast.com) [www.enginplast.com](http://www.enginplast.com) [www.enginplast.com](http://www.enginplast.com)



- Granulators
- Feeding systems
- Gravimetric dosers
- Volumetric dosers

# Technical data - Control panel - Uses

## Technical Data

Model	um	DPP 15/30	DPP 15/50	DPP 15/80	DPP 15/100
Throughput (max)	kg/h	36	165	1000	1500
Throughput (min)	kg/h	0,6	2,8	16	25
Metering unit control power	Kw	0,18	0,18	0,18	0,37
Loading Hopper Capacity	dmc	30	60	60	80
Dimensions (AxBxC)	mm	590x510x840	620x510x915	680x510x940	710x510x940
Weight	kg/h	36	38	40	42

## Control panel



**APPLICATION** • Extrusion

**MATERIALS** • Powder • Grinded material

### ADVANTAGES

- Blends removal beside the machine.
- Quick product change over.
- Costs reduction of personnel in charge of blends preparation and storage.

## Dimensions

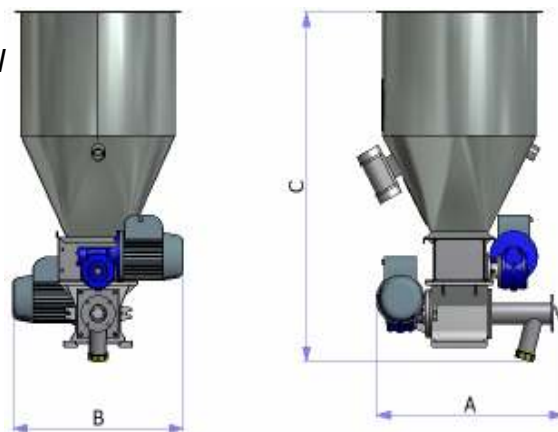

## Uses



\* NOTE : Technical data and images are indicative only and subject to possible changes. Engin Plast reserves the right to make changes for improvement without prior notice.



### Address

Via per Zerbinata 29/A  
44012 Bondeno (Fe) - Italy  
P.iva e C.F. IT 01515370383 REA 174026

### Contacts

Web : [www.enginplast.com](http://www.enginplast.com)  
Mail : [sales@enginplast.com](mailto:sales@enginplast.com)  
Telephone: +39 0532 897178 - Fax: +39 0532 896362

