

Pinza pneumatica a 2 griffe ad azione parallela autocentrante (serie SH)

- Azionamento a doppio effetto.
- Meccanismo di autocentraggio esclusivo.
- Predisposta per sensori magnetici ed induttivi (1).
- Basso peso ottenuto con una costruzione interamente in lega leggera (2).
- Grasso alimentare FDA-H1.

2-jaw parallel self-centering pneumatic gripper (series SH)

- Double acting.
- Exclusive self-centering system.
- Ready for magnetic and inductive sensors (1).
- Light weight, due to its alloy construction (2).
- FDA-H1 food-grade grease.



SH8080

SH80150

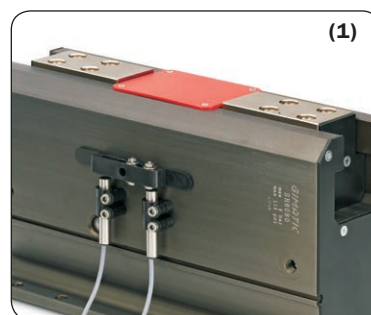

(1)



SH6360

SH63120



(2)

	SH6360	SH63120	SH8080	SH80150
Fluido Medium	Aria compressa filtrata, lubrificata / non lubrificata Filtered, lubricated / non lubricated compressed air			
Pressione di esercizio Operating pressure range	1 ÷ 8 bar			
Temperatura di esercizio Operating temperature range	5° ÷ 60°C.			
Forza di serraggio per griffa in apertura a 6 bar Opening gripping force at 6 bar on each jaw	800 N		1250 N	
Forza di serraggio totale in apertura a 6 bar Opening total gripping force at 6 bar	1600 N		2500 N	
Forza di serraggio per griffa in chiusura a 6 bar Closing gripping force at 6 bar on each jaw	800 N		1250 N	
Forza di serraggio totale in chiusura a 6 bar Closing total gripping force at 6 bar	1600 N		2500 N	
Corsa totale Total stroke	±1 mm 60 mm	120 mm	80 mm	150 mm
Tempo di chiusura senza carico Closing time without load	0.2 s	0.3 s	0.4 s	0.6 s
Consumo d'aria per ciclo Cycle air consumption	308 cm ³	515 cm ³	654 cm ³	1033 cm ³
Peso Weight	2.6 kg	5.2 kg	5 kg	9 kg

Dimensioni (mm) / Dimensions (mm)

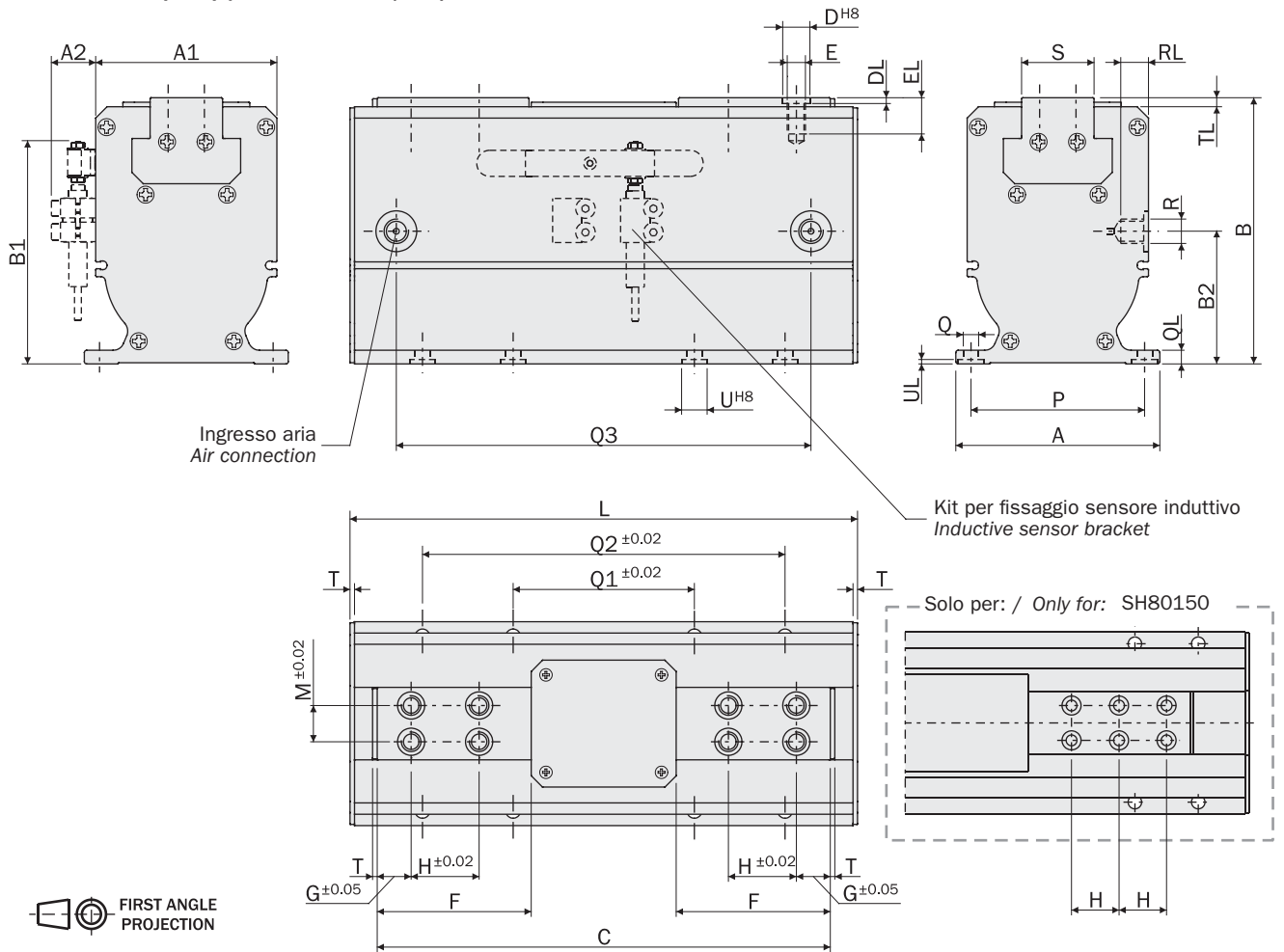

	SH6360	SH63120	SH8080	SH80150
A	90	90	115	115
A1	80	80	95	95
A2	19.5	19.5	19.5	19.5
B	117.5	117.5	161	161
B1	98	98	121.5	121.5
B2	58.5	58.5	72.5	72.5
C	200	270	240	360
D ^{H8}	Ø12 H8	Ø12 H8	Ø12 H8	Ø12 H8
DL	2.6	2.6	2.6	2.6
E	M8	M8	M8	M8
EL	16	16	16	16
F	68	73	78	102.5
G ^{±0.05}	15	15	15	15
H ^{±0.02}	30	30	30	30
L	224	394	284	434
M ^{±0.02}	16	16	22	22
P	77	77	100	100
Q	Ø6.5	Ø6.5	Ø8.5	Ø8.5
QL	6	6	8	8
Q1 ^{±0.02}	80	80	140	140
Q2 ^{±0.02}	160	160	220	220
Q3	183	353	240	390
R	1/8"Gas	1/8"Gas	1/8"Gas	1/8"Gas
RL	8	8	8	8
S	32	32	40	40
T	2	2	2	2
TL	4	4	4	4
U ^{H8}	Ø9 H8	Ø9 H8	Ø12 H8	Ø12 H8
UL	2.6	2.6	2.6	2.6

Fissaggio

La pinza può essere montata in posizione fissa oppure su parti in movimento: in questo caso va considerata la forza d'inerzia cui la pinza ed il suo carico sono sottoposti.

La flangia permette il fissaggio sia dall'alto che dal basso. Utilizzare almeno 4 viti (SB) e 2 boccole di centraggio (UB).

Fastening

The gripper can be fastened to a static or moving part.

When on a moving part, you must pay attention to the forces created by inertia over the gripper and its load.

The flange allows the gripper fastening both from the top and from the bottom.

Use at least 4 screws (SB) and 2 centering sleeves (UB).

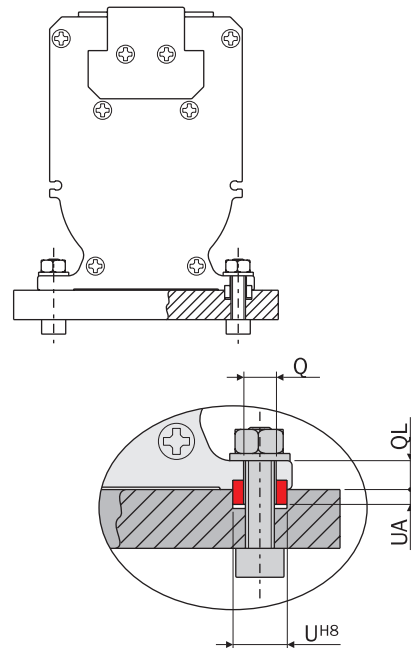
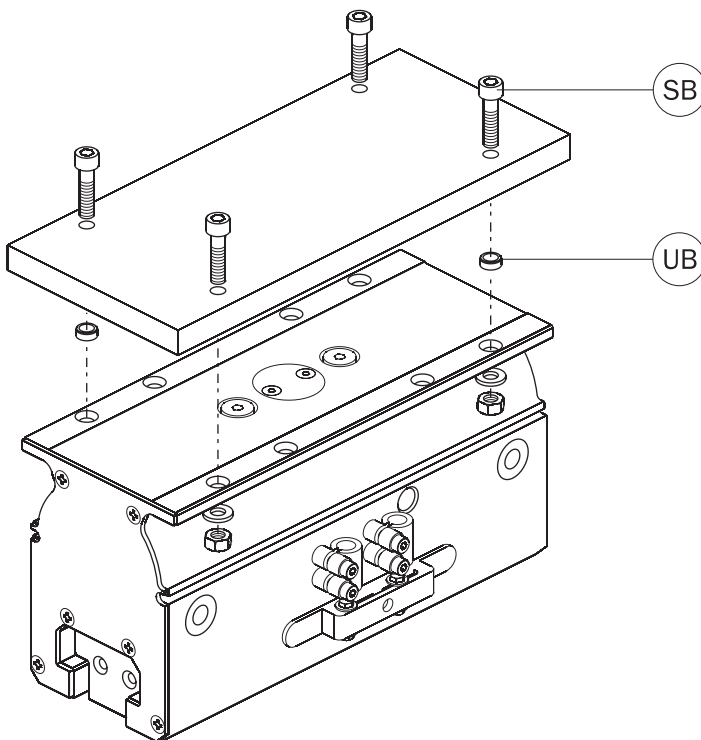
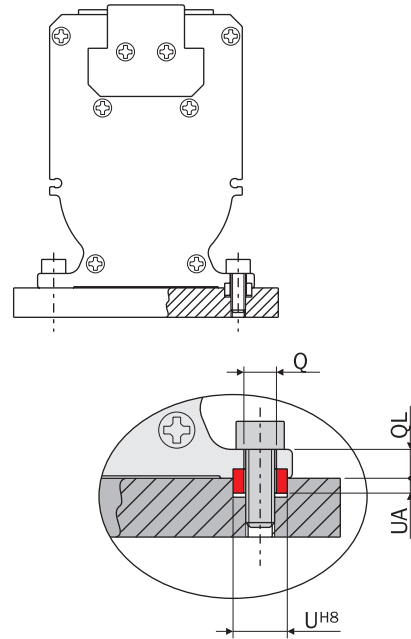
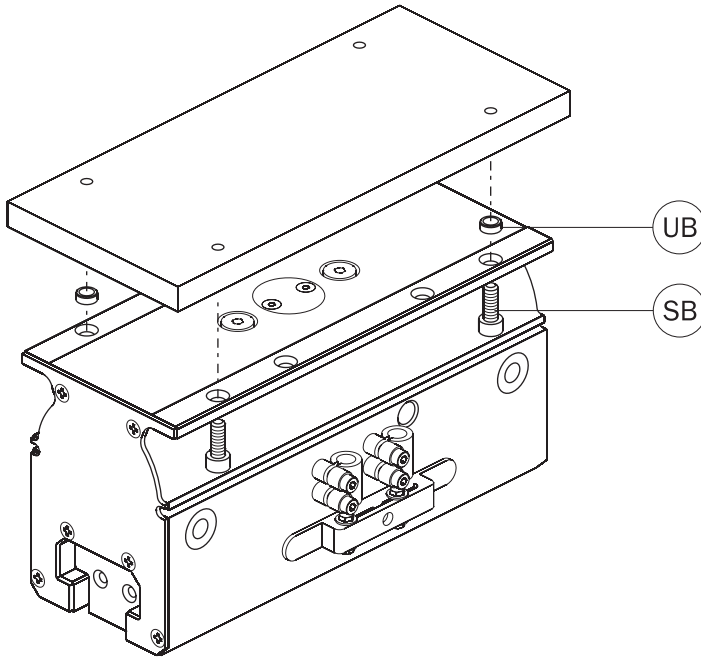

Costruire le dita di presa il più possibile corte e leggere.
Fissarle con 4 viti (SC) e almeno 2 boccole di centraggio (UC).

The gripping tools must be as short and light as possible.
They must be fastened by 4 screws (SC) and at least 2 centering sleeves (UC).

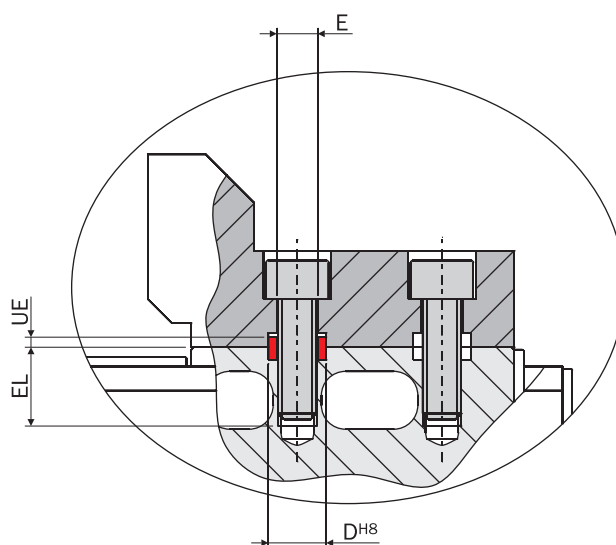
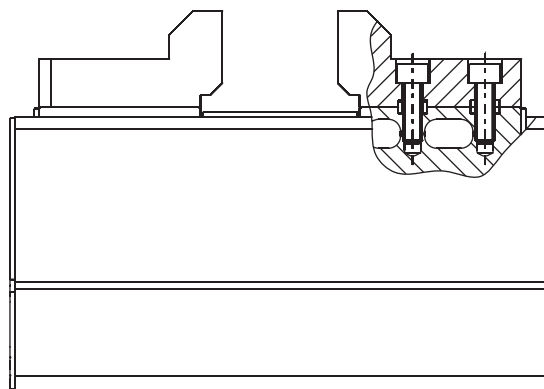
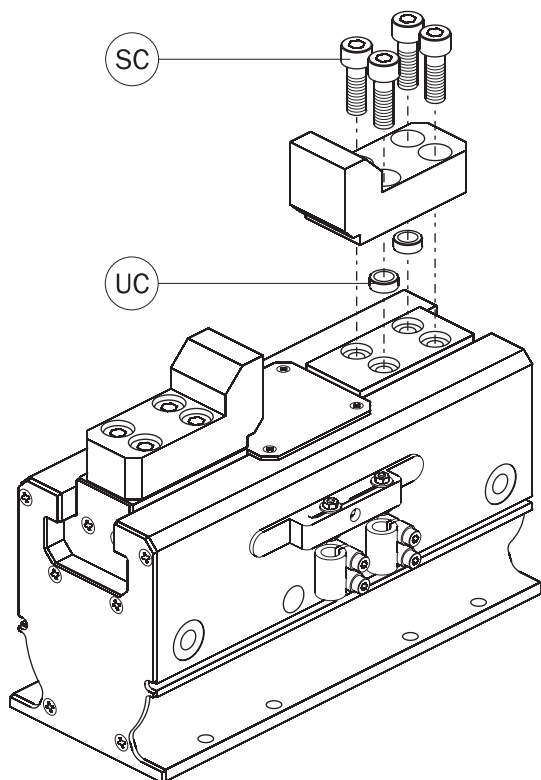

Nella confezione della pinza sono fornite 4 boccole di centraggio (UC) per le dita di presa e 2 boccole (UB) per il corpo.

4 centering rings (UC) for the gripping tools and 2 centering sleeves (UB) for the housing are supplied in the packaging.

	SH6360 / SH63120	SH8080 / SH80150
SB	M6	M8
UB	Ø9 H=4	Ø12 H=5
Q	Ø6.5	Ø8.5
QL	6	8
U	Ø9 H8	Ø12 H8
UA	1.4	2.4
SC	M8	M8
UC	Ø12 H=5	Ø12 H=5
D	Ø12 H8	Ø12 H8
UE	2.4	2.4
E	M8	M8
EL	16	16

Forza di serraggio

I grafici mostrano la forza per griffa espressa dalla pinza in funzione della pressione, del braccio di leva Z e del disassamento del punto di presa X.

La pinza è a doppio effetto e può quindi essere usata per afferrare un pezzo sia dall'esterno che dall'interno.

La forza di serraggio è la stessa in apertura e in chiusura.

Gripping force

The graphs show the gripping force on each jaw, as a function of the operating pressure, the gripping tool length Z and the overhanging X.

The gripper is double-acting for either external or internal gripping applications.

The gripping force is the same in both directions.

La forza indicata in questi grafici è riferita alla singola griffa. La forza totale è il doppio.

The force shown in these graphs refers to one jaw. The total force is double.

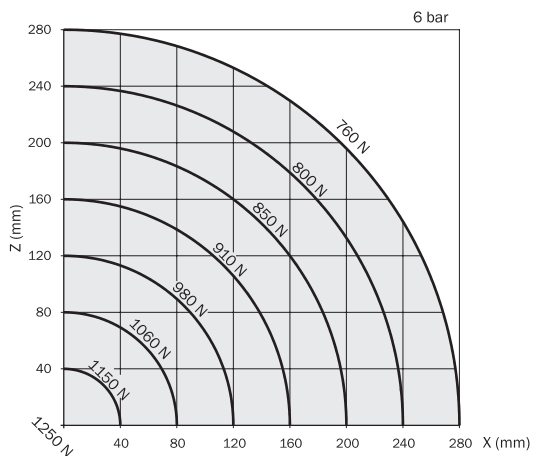
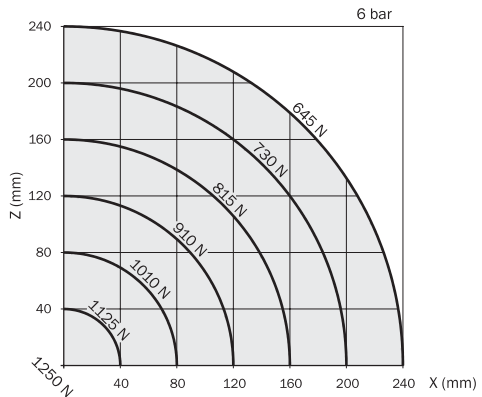
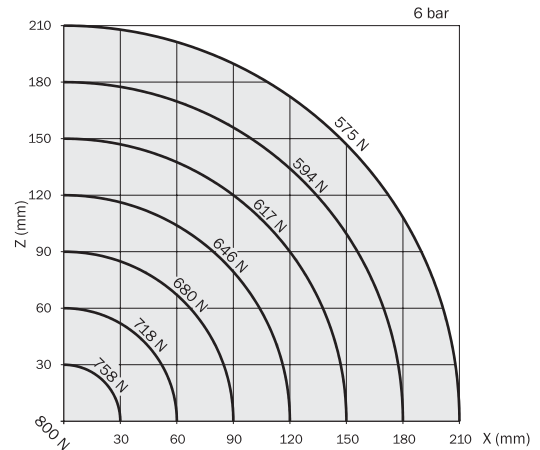
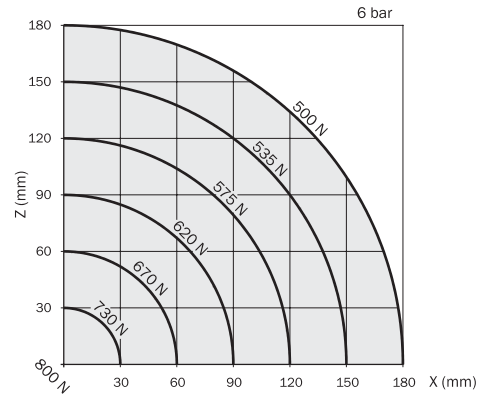
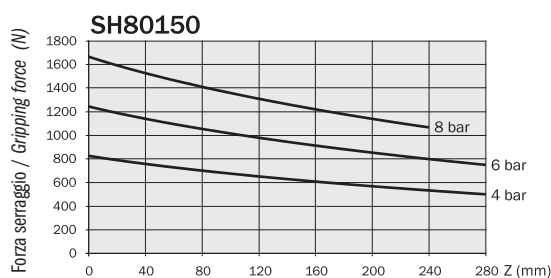
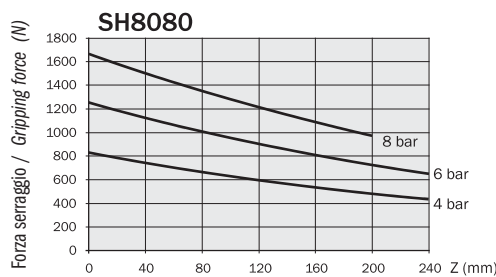
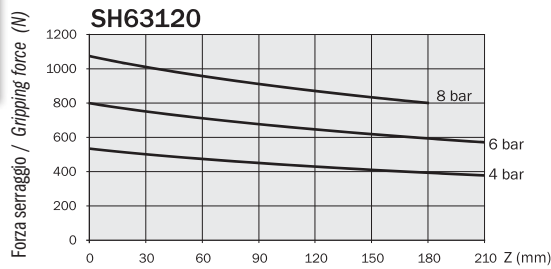
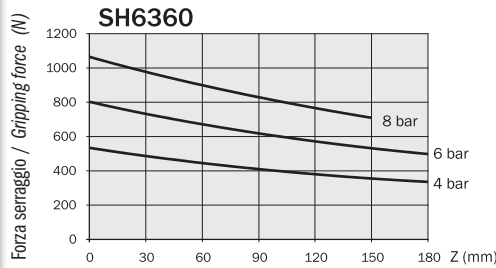
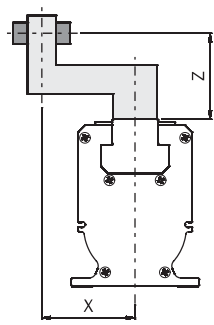

Carichi di sicurezza

Consultare la tabella per i carichi massimi ammissibili. Forze e coppie eccessive possono danneggiare la pinza e causare difficoltà di funzionamento compromettendo la sicurezza dell'operatore.

F_s , $M_x s$, $M_y s$, $M_z s$, sono i carichi massimi ammissibili in condizioni statiche, cioè con le griffe ferme.

F_d , $M_x d$, $M_y d$, $M_z d$, sono i carichi massimi ammissibili in condizioni dinamiche, cioè con le griffe in movimento.

Inoltre sono riportate le masse ammissibili (m) per ogni dito di presa in funzione del tempo di apertura o chiusura. Usare i regolatori di flusso (non forniti) per ottenere la velocità desiderata.

Safety loads

Check the table for maximum permitted loads.

Excessive forces or torques can damage the gripper, cause functioning troubles and endanger the safety of the operator. F_s , $M_x s$, $M_y s$, $M_z s$, are maximum permitted static loads. Static means with motionless jaws.

F_d , $M_x d$, $M_y d$, $M_z d$, are maximum permitted dynamic loads. Dynamic means with running jaws.

The following tables show the specified maximum loads (m) on each gripping tool as function of closing or opening time. Use flow controllers (not supplied) to get the proper speed.

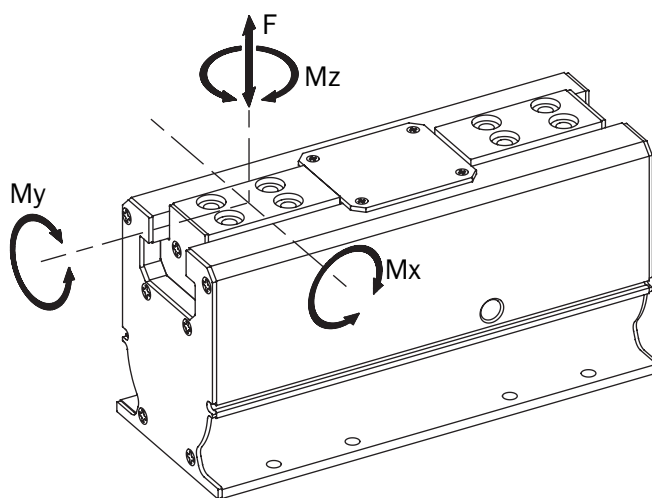

	SH6360	SH63120	SH8080	SH80150
F_s	2000 N	3000 N	4000 N	6000 N
$M_x s$	100 Nm	150 Nm	200 Nm	300 Nm
$M_y s$	50 Nm	75 Nm	100 Nm	150 Nm
$M_z s$	100 Nm	150 Nm	200 Nm	300 Nm
F_d	20 N	30 N	40 N	60 N
$M_x d$	2 Nm	3 Nm	4 Nm	6 Nm
$M_y d$	1 Nm	1.5 Nm	2 Nm	3 Nm
$M_z d$	2 Nm	3 Nm	4 Nm	6 Nm
m 0.9s	-	-	4 kg	6 kg
m 0.6s	2 kg	2.5 kg	3 kg	4 kg
m 0.4s	1.5 kg	1.8 kg	2 kg	-
m 0.3s	1 kg	1.2 kg	-	-
m 0.2s	0.7 kg	-	-	-

Sensori

Il rilevamento della posizione di lavoro può essere effettuato con sensori magnetici (opzionali), che rilevano i magneti sul pistone, oppure con sensori induttivi (opzionali), che rilevano la presenza delle viti inserite nell'appendice (J). Questa si fissa alla griffa, per mezzo dell'apposita vite (K) presente nel kit per i sensori induttivi. I sensori induttivi devono avere diametro 4mm.

Codici di ordinazione dei sensori induttivi:

SI4M225-G	NPN	Cavo 2.5m / 2.5m cable
SI4N225-G	PNP	Cavo 2.5m / 2.5m cable

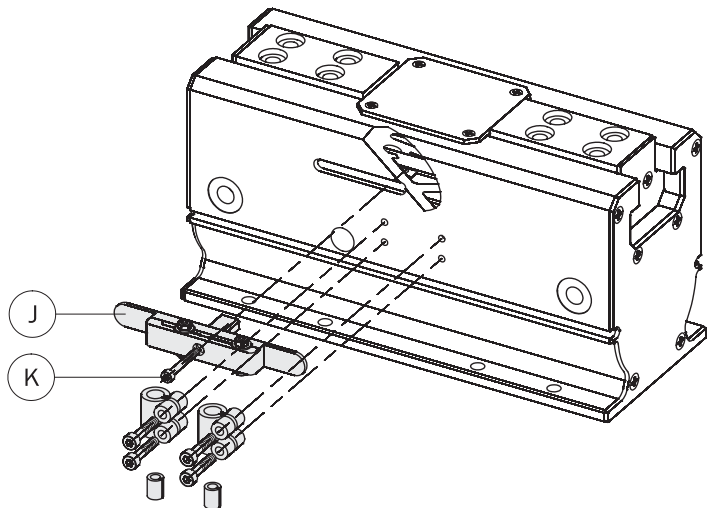
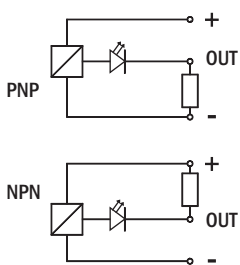

Il kit per il fissaggio dei sensori induttivi è fornito nella confezione della pinza.

The accessories to fix the inductive sensors are supplied in the packaging.

Sensors

The operating position can be checked by magnetic sensors (optional), detecting the magnets on the piston, or by inductive sensors (optional), detecting the screws on the appendix (J). This is to fix on the jaw, with the screw (K) supplied in the accessory pack for the inductive sensors. Use 4mm diameter inductive sensors.

Ordering codes of the inductive sensors:

I sensori magnetici utilizzabili sono i codici Gimatic:

SN4N225-G	PNP	Cavo 2.5m / 2.5m cable
SN4M225-G	NPN	Cavo 2.5m / 2.5m cable
SN3N203-G	PNP	Connettore M8 / M8 snap plug connector
SN3M203-G	NPN	Connettore M8 / M8 snap plug connector
SS4N225-G	PNP	Cavo 2.5m / 2.5m cable
SS4M225-G	NPN	Cavo 2.5m / 2.5m cable
SS3N203-G	PNP	Connettore M8 / M8 snap plug connector
SS3M203-G	NPN	Connettore M8 / M8 snap plug connector

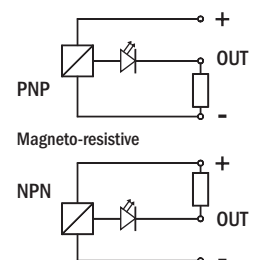

The magnetic sensors from Gimatic are the codes:

Connessione pneumatica

La pinza si alimenta con aria compressa dai fori laterali (P e R) montandovi i raccordi dell'aria ed i relativi tubi (non forniti).

Aria compressa in P: apertura della pinza.
Aria compressa in R: chiusura della pinza.

La pinza è azionata con aria compressa filtrata (5÷40 µm) non necessariamente lubrificata.

La scelta iniziale, lubrificata o non lubrificata, deve essere mantenuta per tutta la vita della pinza.

L'impianto pneumatico deve essere pressurizzato gradualmente, per evitare movimenti incontrollati.

Compressed air feeding

The compressed air feeding can be accomplished on the lateral air ports (P and R) with fittings and hoses (not supplied).

Compressed air in P: gripper opening.
Compressed air in R: gripper closing.

The compressed air, must be filtered from 5 to 40 µm. Maintain the medium selected at the start, lubricated or not, for the complete service life of the gripper.

The pneumatic circuit must be pressurized progressively, to avoid uncontrolled movements.



Circuito pneumatico

Possibili inconvenienti sul circuito di alimentazione dell'aria compressa:

- 1- Oscillazioni di pressione.
- 2- Riempimento pinza vuota all'avvio.
- 3- Improvvisa mancanza di pressione.
- 4- Velocità di azionamento eccessiva.

Accorgimenti per risolvere i problemi:

- 1- Serbatoio esterno (A).
- 2- Valvola di avviamento progressivo (B).
- 3- Valvole di sicurezza (C).
- 4- Regolatori di flusso (D).

Pneumatic circuit

Possible problems on a compressed air circuit:

- 1- Pressure variation.
- 2- Pressurizing with empty cylinder.
- 3- Sudden pressure black-out.
- 4- Excessive speed of the jaws.

Possible solutions:

- 1- Compressed air storage (A).
- 2- Start-up valve (B).
- 3- Safety valve (C).
- 4- Flow controller (D).

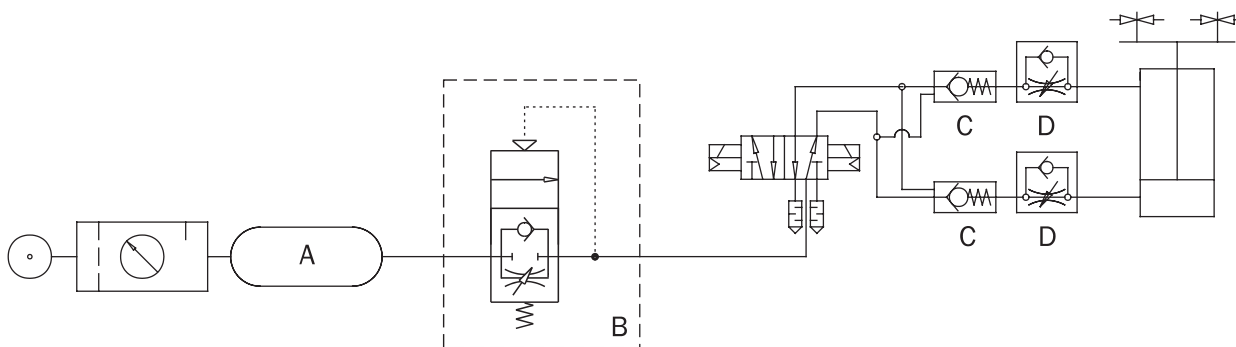

Avvertenze

Evitare il contatto con sostanze corrosive, spruzzi di saldatura, polveri abrasive, che potrebbero danneggiare la funzionalità della pinza.

Per nessun motivo, persone od oggetti estranei devono entrare nel raggio d'azione della pinza.

La pinza non deve essere messa in servizio prima che la macchina di cui fa parte sia stata dichiarata conforme alle disposizioni di sicurezza vigenti.

Caution

Never let the gripper come into contact with corrosive substances, soldering splashes or abrasive powders as they may damage the gripper.

Never let non-authorized persons or objects stand within the operating range of the gripper.

Never operate the gripper if the machine on which it is fitted does not comply with safety laws and standards of your country.

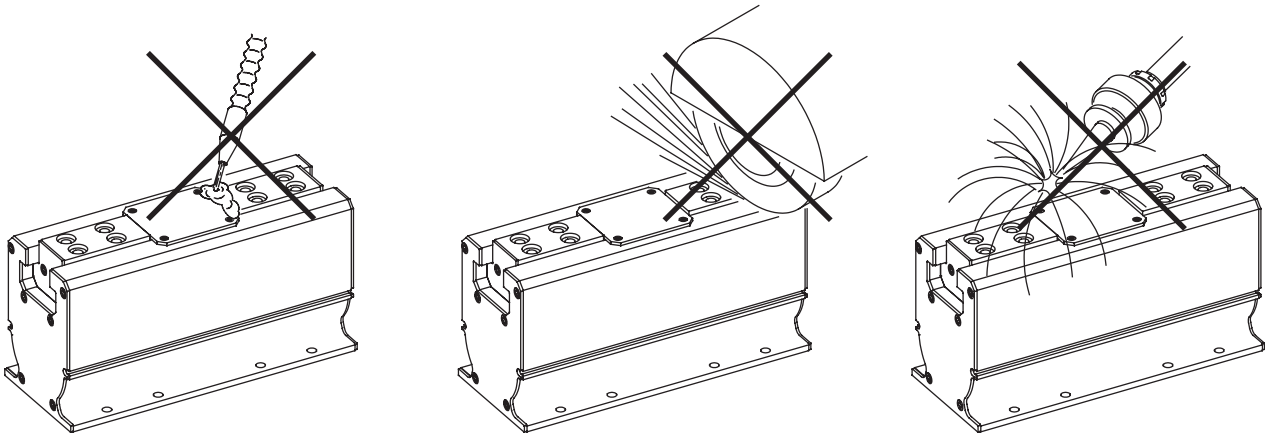
**Manutenzione**

La pinza va ingrassata ogni 5 milioni di cicli con:

- BERULUB FG-H 2 EP
(Lubrificante NSF H1 Registrazione No. 140486).

Maintenance

Grease the gripper after 5 million cycles with:

- BERULUB FG-H 2 EP
(Lubricant NSF H1 Registration No. 140486).

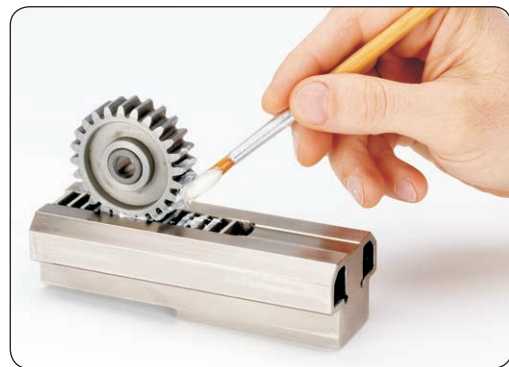

Elenco delle parti / Part list

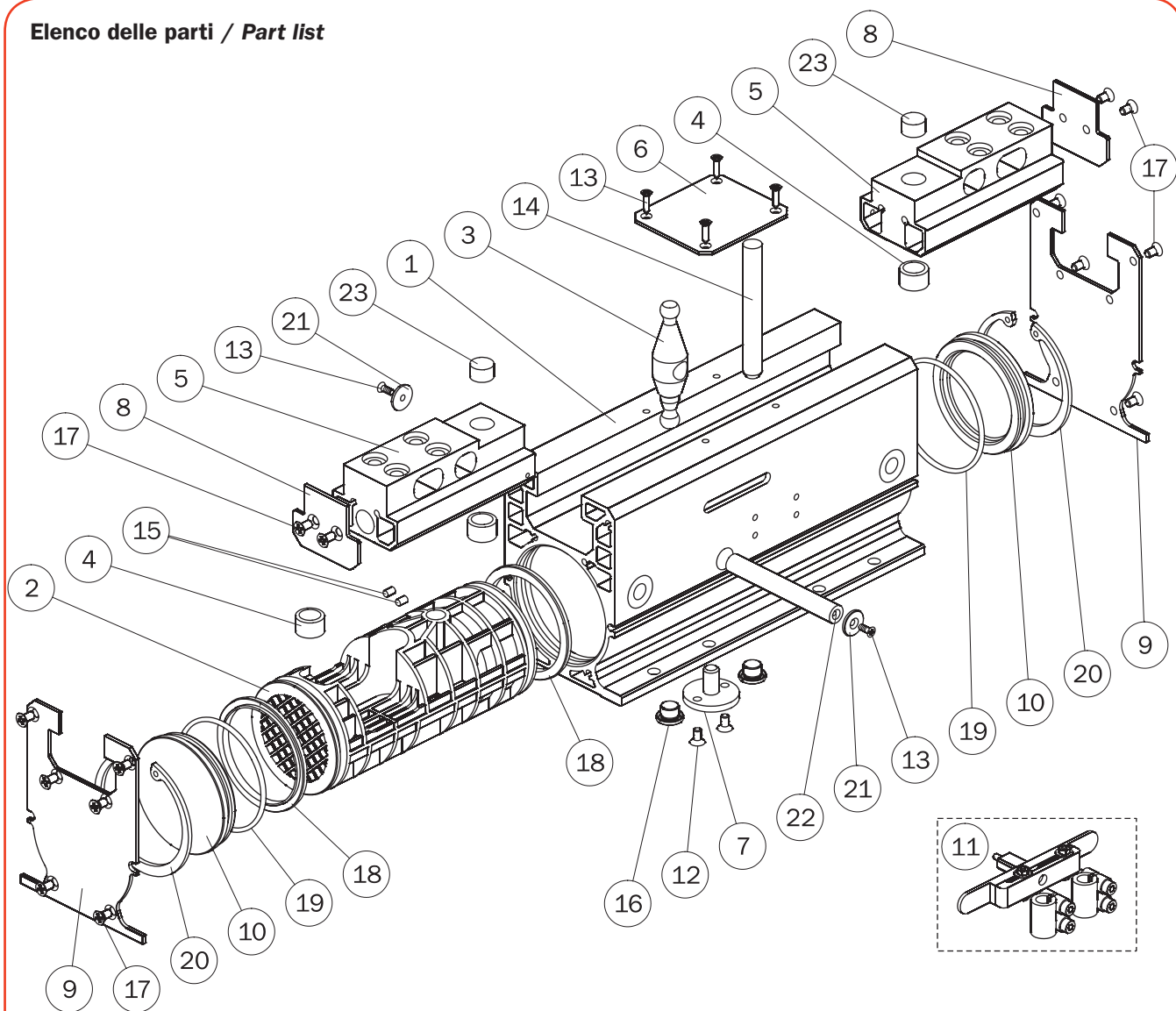

	SH6360	SH8080		
1	Corpo pinza	SH6360-01	SH8080-01	Gripper housing
2	Pistone	SH6360-05	SH8080-05	Piston
3	Leva	SH6360-03	SH8080-03	Lever
4	Boccola	SH6360-10	SH8080-10	Bush
5	Griffa	SH6360-02	SH8080-02	Jaw
6	Copertura	SH6360-08	SH8080-08	Upper cover
7	Finecorsa	SH6360-09	SH8080-09	End-stroke device
8	Coperchio griffa	SH6360-11	SH8080-11	Jaw cover
9	Coperchio corpo	SH6360-13	SH8080-13	Housing cover
10	Tappo	SH6360-04	SH8080-04	Plug
11	Supporto sensori	SHC001	SHC000	Sensor bracket
12	Vite	VITE-305 (M4x8 mm UNI5933 Z/B)	VITE-305 (M4x8 mm UNI5933 Z/B)	Screw
13	Vite	VITE-035 (M3x8 mm DIN965A INOX A2)	VITE-035 (M3x8 mm DIN965A INOX A2)	Screw
14	Spina di riferimento	SH6360-21	SH8080-21	Dowel pin
15	Magnete	PAR-06-7	PAR-06-7	Magnet
16	Tappo	107-G1/8	107-G1/8	Plug
17	Vite	VITE-319 (M4x8 mm DIN7500M)	VITE-319 (M4x8 mm DIN7500M)	Screw
18	Guarnizione dinamica	GUAR-049E (63x53x4.5)	GUAR-128 (Ø2.62x58.42) GUAR-135 (Ø3.53x71.44)	Dynamic gasket
19	O-Ring	GUAR-128 (Ø2.62x58.42)	GUAR-132 (Ø2.62x75.87)	O-Ring
20	Seeger	SEEGER-004N (Ø65 DIN472)	SEEGER-026 (Ø82 DIN472)	Snap-ring
21	Rondella	SH8080-06	SH8080-06	Washer
22	Spina di riferimento	SH6360-07	SH8080-07	Dowel pin
23	Tappo	SH6360-14	VITE-341 (M14x20 DIN 913)	Plug

Elenco delle parti / Part list

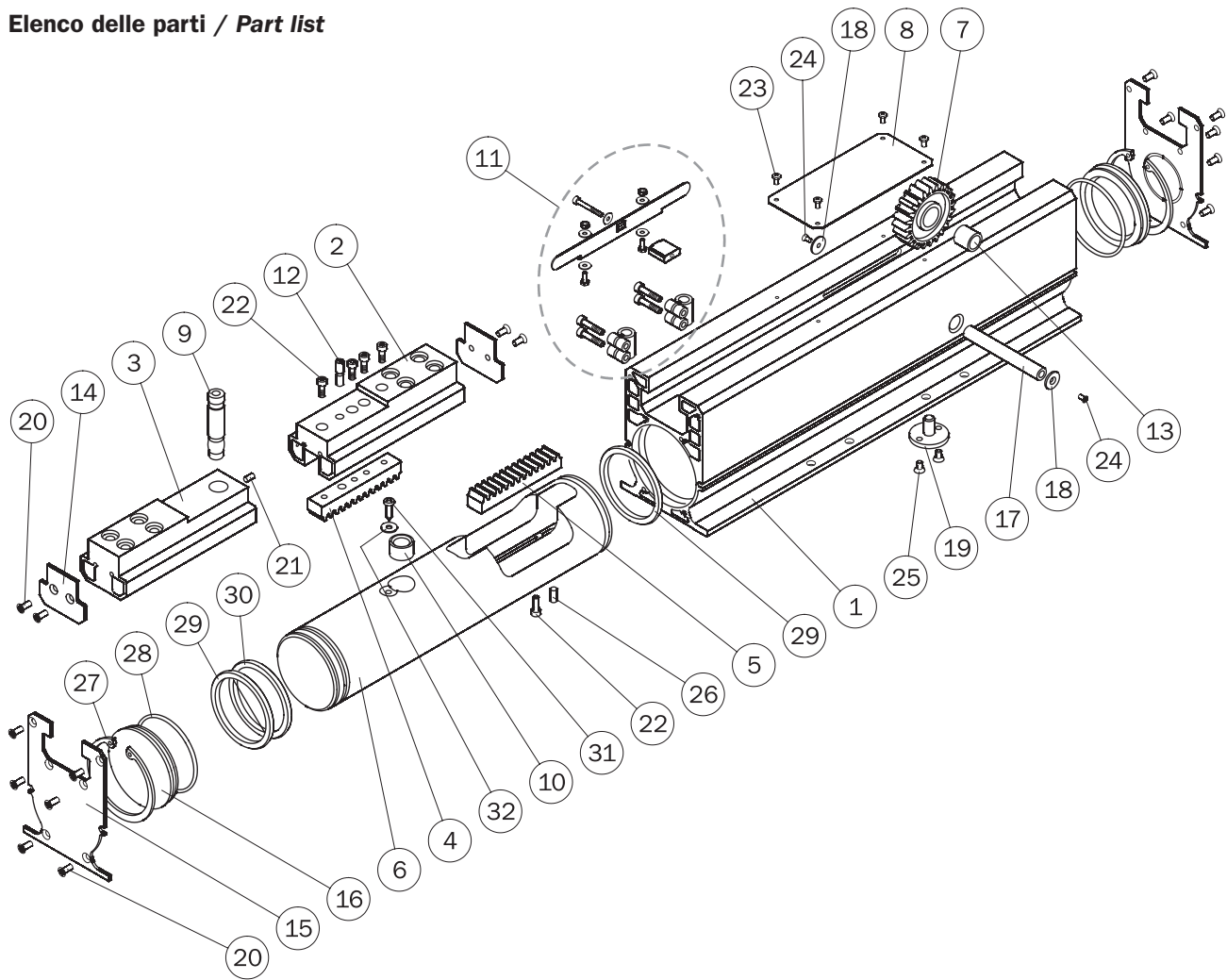

		SH63120			
1	Corpo pinza	SH63120-01		Gripper housing	1
2	Griffa sinistra	SH63120-02		Left jaw	2
3	Griffa destra	SH63120-03		Right jaw	3
4	Crema di griffa	SH63120-04		Jaw rack	4
5	Crema di pistone	SH63120-05		Piston rack	5
6	Pistone	SH63120-06		Piston	6
7	Pignone	SH63120-07		Pinion	7
8	Copertura	SH63120-08F		Upper cover	8
9	Spina di riferimento	SH63120-09		Dowel pin	9
10	Boccola	SH8080-10		Bush	10
11	Supporto sensori	SHC002		Sensor bracket	11
12	Centraggio	SH63120-13		Screw	12
13	Bussola	SH63120-14		Bushing	13
14	Coperchio griffa	SH6360-11		Jaw cover	14
15	Coperchio corpo	SH6360-13		Housing cover	15
16	Tappo	SH6360-04		Plug	16
17	Spina di riferimento	SH6360-07		Dowel pin	17
18	Rondella	SH8080-06		Washer	18
19	Finccorsa	SH6360-09		End-stroke device	19
20	Vite	VITE-319 (M4x8 mm DIN7500M Z/B)		Screw	20
21	Vite senza testa	VITE-043 (M4x8 mm DIN913 INOX A2)		Grub screw	21
22	Vite	VITE-029 (M4x12 DIN912 INOX A2)		Screw	22
23	Vite	VITE-082 (M3x6 mm DIN7985A INOX A2)		Screw	23
24	Vite	VITE-139 (M3x6 mm DIN965A INOX A2)		Screw	24
25	Vite	VITE-305 (M4x8 mm UNI5933 Z/B)		Screw	25
26	Spina di riferimento	SPINA-044 (Ø5x12 mm DIN6325)		Dowel pin	26
27	Seeger	SEEGER-004N (Ø65 DIN472)		Snap-ring	27
28	O-Ring	GUAR-128 (Ø2.62x58.42)		O-Ring	28
29	Guarnizione dinamica	GUAR-049E (63x53x4.5)		Dynamic gasket	29
30	Magnete	T63-10		Magnet	30
31	Vite	VITE-005 (4.2x16 mm DIN7981)		Screw	31
32	Rosetta	VITE-281 (M4)		Washer	32

Elenco delle parti / Part list

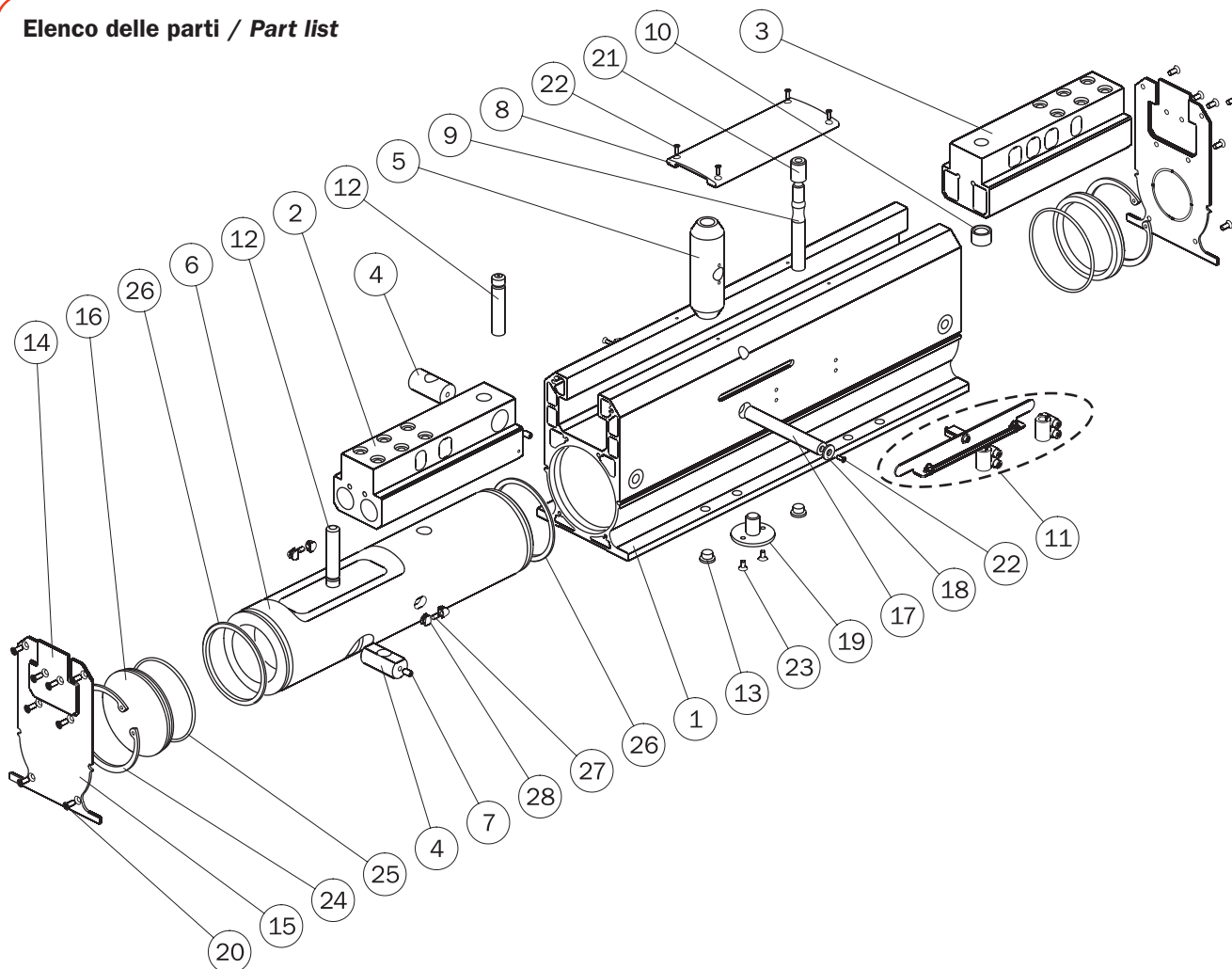

SH80150				
1	Corpo pinza	SH80150-01	Gripper housing	1
2	Griffa sinistra	SH80150-21	Left jaw	2
3	Griffa destra	SH80150-02	Right jaw	3
4	Piede dello stelo	SH80150-22	Rod foot	4
5	Bilanciere telescopico	SH80150-03	Telescopic balance	5
6	Pistone	SH80150-05	Piston	6
7	Vite senza testa	VITE-141 (M5x10 mm DIN914 INOX A2)	Grub screw	7
8	Copertura	SH80150-08	Upper cover	8
9	Spina di connessione	SH8080-21	Connection pin	9
10	Boccola	SH8080-10	Bush	10
11	Supporto sensori	SHC003	Sensor bracket	11
12	Stelo di trasmissione	SH80150-23	Transmission rod	12
13	Tappo	107-G1/8	Plug	13
14	Coperchio griffa	SH8080-11	Jaw cover	14
15	Coperchio corpo	SH8080-13	Housing cover	15
16	Tappo	SH8080-04	Plug	16
17	Fulcro del bilanciere	SH8080-07	Balance pivot	17
18	Rondella	SH8080-06	Washer	18
19	Fincorsa	SH8080-09	End-stroke device	19
20	Vite	VITE-319 (M4x8 mm DIN7500M Z/B)	Screw	20
21	Vite senza testa	VITE-341 (M14x20 mm DIN913)	Grub screw	21
22	Vite	VITE-035 (M3x8 DIN965A INOX A2)	Screw	22
23	Vite	VITE-305 (M4x8 mm UNI5933 Z/B)	Screw	23
24	Seeger	SEEGER-026 (Ø82 DIN472)	Snap-ring	24
25	O-Ring	GUAR-132 (Ø2.62x75.87)	O-Ring	25
26	Guarnizione dinamica	GUAR-126 (80x70x4.5)	Dynamic gasket	26
27	Magnete	PAR-06-7	Magnet	27
28	Porta magnete	RT-12-07	Magnet housing	28